



Metro 150XT RCH Metro 150XT Tunnel RCH

G20/G25/G25.3 (Natural gas) G31 (Propane)



Installation manual (UK/IE)



Store this document in a safe place



Contents

1. Introduction
 2. CE declaration
 3. SAFETY
 - 3.1 General
 - 3.2 Regulations
 - 3.3 Precautions / safety instructions at installation
 - 3.4 Principle of ignition cycle
 4. Removing the packaging
 5. Installation
 - 5.1 Type of gas
 - 5.1.1 Reconstruction to different type of gas
 - 5.2 Gas connection
 - 5.3 Electric connection
 - 5.4 Placing the appliance
 - 5.5 Placing a built-in appliance
 - 5.6 Placing the chimney breast
 - 5.7 Placing the control hatch
 - 5.8 Flue gas discharge system appliances open combustion
 - 5.9 Flue gas discharge / combustion air supply system appliances closed combustion
 - 5.10 Additional instructions
 - 5.11 Glass pane
 - 5.11.1 Removing the glass pane
 - 5.11.2 Fitting the glass pane
 - 5.12 Adjustment of the appliance
 - 5.12.1 Restrictor slide
 - 5.12.2 Air inlet guide
 - 5.13 Placing the wood/pebble set
 - 5.13.1 Wood set
 - 5.13.2 Pebble set
 6. Control
 - 6.1 Remote controls
 - 6.2 Alternative controls
 7. Final inspection
 - 7.1 Gastightness
 - 7.2 Gas pressure/line-pressure
 - 7.3 Ignition main burner
 - 7.4 Flame picture
 8. Maintenance
 - 8.1 Parts
 9. Delivery
 10. Malfunctions
- Appendix 1 Malfunctions
Appendix 2 Tables
Appendix 3 Figures

1. Introduction

DRU, a manufacturer of gas-fired heating appliances, develops and produces products that comply with the highest possible quality, performance and safety requirements. This appliance has a CE label, which means that it complies with the essential requirements of the European Gas Appliance Directive. The appliance is supplied with an installation manual and a user manual. As an installer, you must be certified and competent in the field of gas-fired heating and electricity. The installation manual will give you the information you need to install the appliance in such a way that it will operate properly and safely.

This manual discusses the installation of the appliance and the regulations that apply to the installation. In addition, you will find technical data for the appliance and information on maintenance, any malfunctions that might occur and their possible causes.

The figures can be found at the back of this booklet, in the appendix.

Please, read and use this installation manual carefully and completely, prior to installing this appliance. If you use the DRU Powervent system®, the DRU Smartvent system® or the DRU Maxvent system®, you must carefully and fully read and use the accompanying installation manual as well, prior to its installation.

The following symbols are used in the manuals to indicate important information:

- Work to be performed
- !Tip Suggestions and recommendations
- !Caution You will need these instructions to prevent problems that might occur during installation and/or use.
- !Caution You need these instructions to prevent fire, personal injury or other serious damages.

After delivery, you should give the manuals to the user.

2. CE declaration

We hereby declare that the design and construction of DRU's gas-fired heating appliance comply with the essential requirements of the Gas Appliance Directive.

Product:	gas-fired heating appliance
Type:	Metro 150XT RCH / Metro 150XT Tunnel RCH
EEC directives:	2009/142/EC; 2006/95/EC; 2004/108/EC
Standards:	NEN-EN-613; NEN-EN-613/A1; EN60335-2-102

Internal precautions at the company will guarantee that appliances produced in series comply with the essential requirements of the EC directives in force and the standards derived from them. This declaration will lose its validity if adjustments are made to the appliance without prior written permission by DRU.

You will be able to download a copy of the test certificate via www.druservice.com.

M.J.M. Gelten
 General manager
 Postbus 1021, 6920 BA Duiven
 Ratio 8, 6921 RW Duiven
www.dru.nl

3. SAFETY

3.1 General

- !Caution**
- Please observe the general regulations and the precautions/safety instructions in this manual.
 - First check the exact technical version of the appliance to be installed in Appendix 2, Table 2.

3.2 Regulations

Please install the appliance in accordance with the applicable national, local and constructional (installation) regulations.

3.3 Precautions / safety instructions at installation

Carefully observe the following precautions/safety regulations:

- You should only install and maintain the appliance if you are a certified and competent installer in the field of gas-fired heating and electricity;
- do not make any changes to the appliance;
- if you are installing an appliance that must be built in;
 - use non combustible and heat-resistant materials for the chimney breast, including the top of the chimney breast, the material in the chimney breast and the back wall against which the appliance will be placed. For this you can use both sheet material and stone-like materials;
 - take sufficient measures to prevent temperature of a wall behind the chimney breast becoming too high, including the materials and/or objects behind the wall;
 - comply with the minimum required internal sizes of the chimney breast;
 - vent the chimney breast by means of ventilation holes with a combined passage as stated further down in the text;
 - use heat-resistant electrical wiring;
 - place heat-resistant electrical wiring away from the appliance and as low as possible in the chimney breast. This has to do with the temperature development in the chimney breast.
- if you are installing an appliance type B11 with open combustion: please use a suitable flue gas discharge system that is provided with the CE label;
- if you are installing an appliance with closed combustion: only use the concentric systems supplied by DRU;
- if you are installing a free-standing appliance: place the appliance away from the back wall by the minimum distance stated further down in the text;
- do not cover the appliance and/or do not wrap it in an insulation blanket or any other material;
- make sure that combustible objects and/or materials have a distance from the appliance of at least 500 mm;
- only use the accompanying wood/pebble set and place it exactly as described;
- leave the area around the ionization pin and spark plug free;
- make sure there is no dirt in gas pipes and connections;
- place a gas tap in accordance with applicable regulations;
- prior to putting into operation, check the complete installation for gastightness;
- if your appliance is provided with explosion hatches on its top and/or bottom, you must make sure that they cannot be blocked and check whether they fit well onto the sealing surface, prior to building in the appliance;
- do not ignite the appliance before the gas, discharge and electric connections have been fully installed, first observe the procedure described in chapter 7.3;
- replace broken or torn glass panes.

- !Caution** In case of broken or torn glass panes, the appliance may not be used.

3.4 Principle of ignition cycle

Below you will find a brief description of how this appliance is ignited.

The appliance is off and will be switched on by means of the remote control. The receiver will get the signal to start the ignition process. This signal is passed on to the burner device, after which, if applicable, the relay for the Powervent System® is switched. After an 8 second interval, the ignition on the spark electrodes will start. If no Powervent System® is connected, only the relay will switch and the ignition will start immediately.

The main burner will be ignited at 50% of its capacity.

This will prevent a larger amount of gas in the combustion chamber, if no ignition takes place. When the gas ignites, ionization will have to be detected. In order to make sure the flame has passed over, this will take place at the other side of the burner. When ionization is detected, the gas control will modulate to 100%.

If applicable, the second valve is switched (you will be able to hear a 'click') in order to ignite the second burner.

After ignition of the second burner, the appliance will always go to the full position (full capacity).

This will guarantee that the second burner will actually ignite.

The second burner can be switched on and off manually, by means of the remote control.

In case of switching on manually, the appliance will first return to full load.

!Caution The appliance's control unit is characterized by its stringent safety requirements. It is possible that the burning appliance switches off automatically and then switches back on again. This is not a failure, but a check. The moment the appliance's control unit is connected to mains voltage, the control unit will perform this check every 24 hours. If the appliance is burning at that time, the appliance will extinguish and then start again immediately. If you wish to prevent this, you can remove the plug and insert it again at a time during the 24 hours when the appliance is never or hardly ever burning.

4. Removing the packaging

Note the following items when removing the packaging:

- Remove all packaging materials.
- Remove all supplied components in, on and/or at the appliance.
- Check the appliance and accessories for damages (during transport).
- If necessary, contact your supplier.
- Never install if an appliance is damaged!
- Remove any screws that are used to fix the appliance to a platform or pallet.

!Caution Glass is a ceramic material. Very small irregularities in the glass panes cannot be avoided, but are within the required quality standards.

!Caution Keep plastic bags away from children.

- In Appendix 2, Table 1 you can see which parts you should have after removing the packaging.
- Contact your supplier if you do not have all the parts after you finished removing the packaging.
- Packaging must be disposed of in accordance with the regulations.

5. Installation

Read this manual carefully to ensure the proper and safe installation of the appliance.

!Caution Install the appliance in the order described in this chapter.

- Please install the appliance in accordance with the applicable national, local and constructional (installation) regulations.
- Observe the regulations/instruction in this manual.

5.1 Type of gas

The data plate indicates for which type of gas, gas pressure and for which country this appliance is intended. The data plate can be found on the appliance or can be attached to a chain to which it should remain attached.

!Caution Check whether the appliance is suitable for the type of gas and gas pressure used at the location.

5.1.1 Reconstruction to different type of gas

If you want to convert this appliance into a different type of gas, please contact DRU's service department and ask what is possible. Reconstructions should only be performed by authorized gas installers.

5.2 Gas connection

Place a gas tap in the gas pipe in accordance with the applicable regulations.

The gas connection on the gas control is located next to the receiver (see G Appendix 3, fig. 38).

!Caution Make sure there is no dirt in gas pipes and connections;

The following requirements apply to the gas connection:

- use a gas pipe with the correct dimensions, so that no pressure loss can occur;
- the gas tap must be approved (in the EU this will be the CE mark);
- you should always be able to reach the gas tap.

5.3 Electric connection

In case of a 230 Volt electrical connection, provide proper grounding, if applicable. Place this electrical connection away from the appliance, as low as possible in the chimney breast. This has to do with the temperature development in the chimney breast. If possible, place the receiver after any building work has been completed. If this is not possible:

!Caution Protect the receiver against dust and moisture created during the building process!

5.3.1 Connecting the switch contact (if applicable)

It is possible to operate one or more lamps (in case of several lamps, a maximum of 8A/250VAC/30VDC) via the remote control of the appliance. You could think of the lamps of Dru's lux elements. For this, you can use switch contact B on the receiver (see appendix 3, fig 36). The switch contact is not polar sensitive.

5.3.2 Connecting the Dru Omivent (if applicable)

If the appliance is equipped with a Dru Lux Omnivent system, it can be operated with the remote control and connected (see appendix 3, fig 36, (C)). The supply to this connection is equal to the mains voltage.

5.4 Placing the appliance

- !Caution**
- Always place the appliance with a minimum distance of 500 mm from combustible objects or materials;
 - Place the discharge pipes in such a way that situations with risk of fire can never occur;
 - Always place the appliance in front of a wall of non combustible and heat-resistant material;
 - Always maintain a minimum distance between appliance and back wall, if indicated in the dimensional drawing (see Appendix 3, Fig. 2);
 - Take sufficient measures to prevent temperature of a wall behind the chimney breast becoming too high, including the materials and/or objects behind the wall;
 - Do not cover the appliance and/or do not wrap it in an insulation blanket or any other material;
 - Make sure that the appliance to be installed has a stable position. If applicable, this could be done by fixing the extension legs with self-tapping screws.

- !Caution** When installing an appliance that has to be built in, take the following into account;
- The minimum construction measurements according to Appendix 3, Fig. 1 and 2;
 - The construction height of the appliance, which you can determine yourself.

- Provide a gas connection at the location. For details, see section 5.2.
- Make a passage for the flue gas discharge system or the concentric system with the following diameters; for details, see section 5.8 or 5.9:
 - the pipe diameter +10 mm for a passage through non combustible material;
 - the pipe diameter +100 mm for a passage through combustible material;

!Caution Additional instructions, specifically for the appliance that you are installing, start at chapter 5.10.

5.5 Placing a built-in appliance (if applicable)

Not all built in appliances by DRU are supplied with a control hatch. If it is not included, this control hatch is available separately. We recommend using the Dru control hatch at all times. In this chapter, it is assumed that the appliance is used with a control hatch.

!Caution If you do not use a recommended Dru control hatch, please strictly observe the safeguards and necessary instructions stated in chapters 5.5 to 5.7.

If you are not using the control hatch, please take the following into account as well:

- the accessibility of components that are normally placed in the control hatch;
- the maximum temperature of these components (maximum 60 °C).

The gas control is mounted to the appliance. It must be taken out and placed in the control hatch at a later time. For placing the gas control in the control hatch, see section 5.7.

Proceed as follows:

- Remove the bracket with, amongst other things, the gas control from the appliance by unscrewing the self-tapping screws.
- Place the bracket to which, amongst other things, the gas control is mounted, together with the wiring of the ignition/ionization cable(s), the flexible gas hose(s) and the data plate with chain in the direction of the control hatch.

!Caution

- Make sure there is no dirt in gas pipes and connections;
- Avoid kinks in the pipes.

!Caution

- Make sure the ignition cables cannot come into contact with other wires;
- The data plate should remain connected to the chain.

- Set the height of the appliance using the adjustable feet and
- Make the appliance level at the same time.

!Tip The construction frame for most 2 or 3 sided appliances can be adjusted. This will allow you to connect the construction frame to the chimney breast correctly. For 2 or 3 sided appliances that cannot be adjusted, we would like to refer you to chapter 5.10 'Additional instructions'.

!Caution do not ignite the appliance before the gas, discharge and electric connections have been fully installed, first observe the procedure described in chapter 7.3.

5.6 Placing the chimney breast (if applicable)

In order to provide proper heat discharge, there should be sufficient space around the appliance. The chimney breast should be ventilated sufficiently by means of ventilation holes (incoming and outgoing).

!Caution

- When installing an appliance with mantelpiece, specific dimensions may apply for the opening in the chimney breast.
- When an appliance is built in the floor, please take into account the minimum distances from a combustible floor.
If this applies to your situation, you'll find more information in chapter 5.10 'Additional instructions'.

- !Caution**
- Use non combustible and heat-resistant materials for the chimney breast including the top of the chimney breast, the material in the chimney breast and the back wall of the chimney breast;
 - Make sure the appliance is not carrying the weight of the chimney breast when using stone-like materials;
 - The passage of the ventilation holes (outgoing), which are placed as high as possible, is stated in Appendix 2, Table 2.

- !Caution** When placing the chimney breast, you should take the following into account (see Appendix 3, Fig. 2):
- The location for the control hatch: this must be placed as low as possible;
 - The dimensions of the control hatch; see Placing the control hatch section 5.7;
 - The Dru control hatch is not supplied with all appliances. Nevertheless, we recommend only using a Dru control hatch, which can be supplied separately, if necessary. If you decide not to take this option, you will have to make a 100 cm² ventilation hole that is placed as low as possible, for the benefit of the incoming ventilation.
 - The location of the ventilation holes (V) (outgoing);
 - Maintain a minimum 30 cm distance between the top of the ventilation hole (outgoing) and the ceiling of the house;
 - The measurements of the glass pane, so that it can be placed/removed after placing the chimney breast;
 - The protection of the gas control and the pipes against cement and plaster.
 - If possible, you should place decorative strips, frames, etc., after any required structural work has been completed. Avoid the use of painter's tape. If this is not possible: please use good quality painter's tape and remove it immediately after plastering or painting work has been completed.

- !Tip** You should preferably apply the ventilation holes (outgoing) on both sides of the chimney breast. You can use DRU ventilation elements.

Prior to completely closing the chimney breast, check:

- whether the discharge / concentric system is placed correctly;
- whether the channels, fixing brackets and possible clip bindings, which cannot be reached after installation, are fastened by means of self-tapping screws.

- If applicable, do not plaster on or over the edges of the construction frame, because:
 - the heat of the appliance could cause cracks;
 - it will no longer be possible to remove/place the glass pane.
- When using stone-like materials and/or plaster finishing, allow the chimney breast to dry for at least six weeks prior to taking the appliance into operation in order to prevent cracks.

5.7 Placing the control hatch (if applicable)

The control hatch (also see paragraphs 5.5 and 5.6) is placed as low as possible in the chimney breast.

- !Caution**
- The bottom of the control hatch may not be placed higher in the appliance than the burner surface.
 - Place control hatch and bracket with gas control and accessories indoors in a dry place only!

A number of components are placed in the control hatch, such as data plate, gas control, receiver belonging to the remote control and, if applicable, the components belonging to the DRU Powervent System®.

Place the control hatch as follows, see Appendix 3, Fig. 3 for details:

- Make an opening in the chimney breast, as described in the manual for the control hatch.

- !Tip** The opening in the chimney breast may be made horizontal and vertical.

- Place the inner frame (A); unscrew bolts (D and F) for this.

- !Caution**
- The inner frame should be placed in the correct way. Two positions are possible. Placing the inner frame with a rotation of 180° is not allowed (see Appendix 3, fig. 4).

- !Tip**
- When the chimney breast is made of bricks, the inner frame can be built with bricks at the same time;
 - When using a different material, you can glue the inner frame or fix it with four flush screws.

- Remove the bracket with the components (B) from the appliance.

- Mount the bracket with components to the inner frame (A). Proceed as follows:
 - Unwind the cables. This will, amongst other things, prevent a poor operation of the ignition.
 - Unwind the flexible gas pipe(s).
 - Mount the bracket with components to the inner frame (A). The lock hole will fall into the allen screw (C); the hole at the bottom will fall over the head of the allen screw (D).
 - Fix the bracket with allen screw (C).

- !Caution**
- Avoid kinks in the pipes.
 - Do not lay the cables of the ionization pins and spark electrodes along metal parts.

- Make sure there is no dirt in gas pipes and connections.
- Connect the gas pipe with gas tap.
- Bleed the gas pipe.

!Tip If the gas tap is closed, you can simply remove the bracket with components by loosening the compression fitting under the gas control and loosening the allen screw (C) a few strokes. The bracket with components can now be lifted and removed from the control hatch in a forward movement.

- Connect the 230 V mains voltage with earth connection. Various types of plug connections are supplied. The type of plug depends on the country where the appliance is placed.
- Place the data plate in its intended clamp (G).
- Mount the outer frame with door (E) to the inner frame using two allen screws (D and F).

!Tip You can place the outer frame in such a way, that the door turns to the left or to the right.

!Caution Always close the control hatch with the lock (H) because of the electricity behind the door (230V). You can operate the lock with a fitting flat object.

5.8 Flue gas discharge system at appliances with an open combustion (type B11)

For connection to an existing chimney without a discharge pipe or flexible SS discharge – only allowed in Great Britain – the instructions provided in the separately supplied booklet 'Fitting into a conventional class 1 chimney' apply. In addition to the installation instructions, this booklet also contains supplementary tests.

5.8.1 General

The appliance's type of discharge system is stated in Appendix 2, Table 2.

The appliance must be connected to an existing or newly to be built chimney, according to the applicable, national, local and constructional (installation) regulations.

5.8.2 Connection of flue gas discharge system (if a class 1 chimney is not applicable)

At least a 3 metre discharge pipe or a flexible SS discharge should be connected to the appliance.

Bends in the flue gas discharge system are not allowed.

- !Caution**
- Maintain a distance of at least 50 mm between the outside of the concentric system and the walls and/or ceiling. If the system is built in (for instance) a cove, it should be made with non combustible material all around it;
 - Use heat-resistant insulation material when passing through combustible material;
 - Use a flue gas discharge system with the correct diameter, and which is provided with the CE mark;

!Caution Some heat-resistant insulation materials contain volatile components that will spread an unpleasant smell for a prolonged time; these are not suitable.

- Place the flue gas discharge system as follows:
- Connect the pipe pieces or flexible SS discharge.
 - You should only install the appliance in a well ventilated room which complies with the applicable national, local and constructional (installation) regulations, in order to guarantee sufficient air supply.

!Caution

- In case of a house with a mechanic exhaust system and/or an open kitchen with cooker hood, a permanent ventilation hole is required in the area surrounding the appliance; for this application, please refer to the gas installation regulations and local legislation.

5.9 Flue gas discharge /combustion air supply system at appliances with a closed combustion

5.9.1 General

The appliance's type of discharge system is stated in Appendix 2, Table 2.

The appliance is connected to a combined flue gas discharge/combustion air supply system, hereafter referred to as the concentric system.

The passage to the outside can be made with both a wall terminal and roof terminal.

If necessary, you can also use an existing chimney (see section 5.9.4).

- !Caution**
- Only use the concentric system supplied by DRU. This system has been tested in combination with the appliance. DRU cannot guarantee a proper and safe operation of other systems and does not accept any responsibility or liability for this;
 - For connecting to an existing chimney you should only use the chimney kit supplied by DRU.

The concentric system is constructed from (the flue spigot of) the appliance.

If, due to constructional circumstances, the concentric system is placed first, it is possible to connect the appliance by means of a telescopic pipe piece.

5.9.2 Construction of the concentric system

Depending on the construction of the concentric system the appliance will have to be further adjusted with possibly a restrictor slide or air inlet guide.

See Tables 4 and 6 for determining the correct adjustment and section 5.9, 'Adjustment of the appliance' for the method of working.

The concentric system with wall or roof terminal has to comply with the following conditions:

- In appendix 2, table 4 or 5 you can find whether a concentric pipe should be connected and what the minimum vertical length would have to be;
- Determine the permissibility of the required discharge.

When using a **wall terminal** the following applies:

- The total vertical pipe length, when using a wall terminal, may have a maximum length that you can find in Appendix 2, Table 4;
- The minimum vertical pipe length, when using a wall terminal, can be found in appendix 2, table 4;
- The total horizontal pipe length, when using a wall terminal, may have a maximum length that you can find in Appendix 2, Table 4 (without wall terminal; see Appendix 3, Fig. 5).

When using a **roof terminal** the following applies:

- The construction of the chosen system, when using a roof terminal, must be permissible according to Appendix 2, Table 5 (See the method of working described below).

The working method below indicates how the permissibility is determined of a concentric system when using a roof terminal.

- 1) Count the number of 45° and 90° bends required;
- 2) Count the total number of whole metres of horizontal pipe length;
- 3) Count the total number of metres of vertical and/or sloping pipe length (roof terminal excluded);
- 4) In the first 2 columns of Table 5, look for the number of bends required and the total horizontal pipe length;
- 5) In the top row of Table 5, look for the required total vertical and/or sloping pipe length;
- 6) If you end up in a box with a letter, the concentric system chosen by you is permissible;
- 7) Use Table 6 to determine how the appliance should be adjusted.

5.9.3 Placing the concentric system

- !Caution**
- Maintain a distance of at least 50 mm between the outside of the concentric system and the walls and/or the ceiling. If the system is built in (for instance) a cove, it should be made with non combustible, heat-resistant material all around it;
 - Use heat-resistant insulation material when passing through combustible material;
 - The rosette of the wall terminal is too small to seal the opening when passing through combustible material. That is why you should first apply a sufficiently large heat-resistant intermediate sheet to the wall. Then, the rosette is mounted on the intermediate sheet.

The roof terminal can end in a sloping and a flat roof.

The roof terminal can be supplied with an adhesive plate for a flat roof or with a universally adjustable tile for a sloping roof.

- !Caution** Some heat-resistant insulation materials contain volatile components that will spread an unpleasant smell for a prolonged time; these are not suitable.

Place the concentric system as follows:

- Build the system up from (the flue spigot of) the appliance.
- Connect the concentric pipe pieces and, if necessary, the bend(s).
- On each connection, apply a clip binding with silicon sealing ring.
- Use a self-tapping screw to fix the clip binding to the pipe on locations that cannot be reached after installation.
- Apply sufficient wall brackets, so that the weight of the pipes does not rest on the appliance.
- Determine the remaining length for the wall or roof terminal and cut it to size, make sure the correct insertion length is maintained.
- Place the wall terminal with the (groove/folded) seam at the top;
- Attach the wall terminal from the outside by means of four screws.

- !Caution** When using the wall terminal, place the terminal with a downward slope of 1 cm / metre towards the outside, in order to prevent rain water from raining in.

5.9.4 Connection to an existing chimney

It is possible to connect the appliance to an existing chimney.

A flexible SS pipe is placed in the chimney with a fitting diameter at the flue gas discharge pipe, for the discharge of flue gases. The surrounding space is used to supply combustion air.

The following requirements apply when connecting to an existing chimney:

- only allowed when used in combination with the special DRU chimney set. The installation regulation is part of the delivery;
- the internal size should be at least 150 x 150 mm;
- the vertical length has a maximum of 12 meters;
- the total horizontal pipe length may have a maximum length that you can find in Appendix 2, Table 4;
- the existing chimney should be clean;
- the existing chimney should be tight.

For setting the appliance, the same conditions/instructions apply as for the concentric system described above.

5.10 Additional instructions

- Attach the appliance to the wall by means of wall brackets and supplied key bolts (see Appendix 3, fig. 1).

5.11 Glass panes

- !Caution**
- Avoid damaging the glass panes during removal/placing.
 - Avoid/remove fingerprints on the glass panes, as they will burn into the glass.

5.11.1 Removing glass pane

When removing the front glass pane, you should follow the next steps (see Appendix 3, fig. 6-17).

- Remove the vertical decorative strips on the left and right of the glass frame by pushing the lip at the top of each strip up, tilting the top of the strip parallel with the glass frame, and then removing the strip.
- Remove the horizontal decorative strip by lifting it on one side and taking it out.
- Unscrew the 4 self-tapping screws in the bottom strip using the socket spanner supplied with the appliance.
- Loosen the 3 self-tapping screws in the fastening strips on both sides 2 turns.

- !Caution** Do not remove the self-tapping screws: leave them in place in the fastening strips.

- Push the 2 top wedges (left and right) down as far as possible.
- Push the 2 bottom wedges upwards as far as possible.
- Press the two fastening strips outwards with your hands as far as possible to avoid damage to the sealing cord.
- Take hold of the top and bottom handgrips and lift the glass frame.
- Pull on the bottom handgrip to tilt the glass frame in its mounting towards you and, at the same time, pull the top of the glass frame towards you as far as possible.

- !Caution**
- Make sure you hold the upper handgrip firmly. If you let go of the handgrip then the glass frame could fall inwards and cause severe damage to both the glass and the appliance.
 - Make sure that you lift the glass frame out of its mounting as straight as possible to avoid damage to the paintwork and the sealing cord.

- Gently allow the glass frame to drop at an angle until it can be removed entirely from the mounting.

5.11.2 Placing glass pane

The glass frame is fitted by using the above procedure, in reverse order.

- !Caution**
- Avoid/remove fingerprints on the glass, since otherwise they will burn into the surface.
 - The self-tapping screws must not be over-tightened, since otherwise they could break or strip the thread: tight=tight.
 - Replace the fastening strip if the sealing cord has come loose.

Pay attention to the following when fitting the glass frame:

- Begin by checking that the two fastening strips are pressed outwards as far as possible to avoid damage to the sealing cord.
- Fit the glass frame.
- Check that the hook at the top of the glass frame is in position in the seating / U-shaped strip.

- !Tip** Pull on the upper handgrip to move the glass frame towards you: if it does not move, then it has been fitted correctly.

- !Caution** Fix the glass frame's bottom strip in place with the 4 self-tapping screws.

- Push both bottom wedges downwards.
- Push the top wedges upwards until the sealing cord of both fastening strips press against the glass.
- Tighten each wedge's self-tapping screw.

!Caution Press on the wedge with your hand to hold it in place while you tighten the screws.

- Tighten the middle self-tapping screw in each fastening strip.
- Fit the horizontal decorative strips.
- Fit the vertical decorative strips.

5.12 Adjustment of the appliance

The appliance has to be set in such a way that it works correctly in combination with the discharge system applied. For that purpose, a restrictor slide is placed and/or the air inlet guide is removed. The conditions for application with wall terminal and roof terminal are stated in Appendix 2, Tables 4, 5 and 6.

This appliance is suitable for PowerVent®. For more information see the PowerVent® Installation Manual.

5.12.1 Air inlet guide

The air inlet guides (L) are located at the bottom (side) of the tray around the burner.

Remove them as follows (see Appendix 3, Fig. 18).

- Unscrew the self-tapping screws (K) from the tray surrounding the burner (M).
- Remove the tray surrounding the burner;
- Unscrew and remove the self-tapping screws;
- Remove the air inlet guides;
- Replace the tray round the burner.
- Screw the self-tapping screws (K) in the tray surrounding the burner (M).

5.12.2 Restrictor slide

The restrictor slide (R) is supplied separately (see Appendix 3, fig. 19).

It is mounted as follows:

- Unscrew the self-tapping screws (S) from the middle plate (T) and remove them.
- Place the restrictor slide.
- Adjust the distance of the restrictor.
 - in case of a 40 mm setting, the restrictor slide is closed to a maximum level;
 - in case of a 55 mm setting, the distance must be set by means of a gauge (see Appendix 3, fig. 20).
- Fix the restrictor slide by using the allen screw (U).
- Remount the middle plate by using the self-tapping screws.

5.13 Placing the wood/pebble set

The appliance is supplied with a wood set or a pebble set.

The vermiculite that is used to fill the burner is black when using the wood set and has a natural colour when using the pebble set.

!Caution The figures do not always show the correct colours.

!Caution Strictly observe the following instructions to prevent unsafe situations:

- only ever use the supplied wood/pebble set;
- only use the glow material (see appendix 3, fig. 27) in combination with the wood set;
- place the wood/pebble set exactly as described;
- make sure the ionization and spark electrodes and the surrounding space remain free (see Appendix 3, fig. 21 up to 24);
- make sure that the slot between the burner tray and the tray surrounding the burner is kept free from objects;
- make sure there is no vermiculite's dust on the burner.

5.13.1 Wood set

The wood set consists of vermiculite (see Appendix 3, fig. 25), chips (see Appendix 3, fig. 26), glow material (see Appendix 3, Fig. 27) and a number of branches (see Appendix 3, fig. 28).

!Caution The figures do not always show the correct colours.

- Remove the frame from the vermiculite tray (see Appendix 3, fig. 29).
- Fill the burner with vermiculite; spread the vermiculite evenly (see Appendix 3, fig. 29). The vermiculite may not come higher than the edge of the burner.

!Caution

- You can influence the flame picture by moving the vermiculite, yet
- the burner deck has to remain covered with vermiculite in order to prevent that the life span of the burner is reduced.

- Fill the vermiculite tray with chips; spread the chips evenly (see Appendix 3, fig. 29).
- Identify branches A up to H (see Appendix 3, fig. 28).

!Tip Use the burn stains on the branches for identification.

- Place branch A across the burner, place the ridge of the branch on the positioning bracket (see Appendix 3, fig. 30a).
- Proceed with branches B, C, D and E (see Appendix 3, fig. 30b).
- Then place branches F up to H (see Appendix 3, fig 30c).

!Caution The branches may not completely cover the burner pattern (see Appendix 3, fig. 31), because:

- the main burner will not ignite properly; which could result in unsafe situations;
- the appliance will become filthy more quickly, as a result of soot;
- the flame picture will be affected.

- If required, spread the glow material over the burner.

!Caution The areas around the ionization and ignition should remain free from glow material.

!Tip Fasten the glow material under chips and/or wood set.

5.13.2 Pebble set

The pebble set consists of vermiculite (see Appendix 3, fig. 25) and pebbles.

!Caution The figures do not always show the correct colours.

- Remove the positioning bracket for the vermiculite tray (see Appendix 3, fig. 32).
- Fill the burner with vermiculite; spread the vermiculite evenly (see Appendix 3, fig. 33a).

!Caution

- You can influence the flame picture by moving the vermiculite, yet
- the burner deck has to remain covered with vermiculite in order to prevent that the life span of the burner is reduced.

- Fill the burner and the vermiculite tray with pebbles.
- Spread the pebbles evenly over one layer (see Appendix 3, fig. 33b and 33c).

!Caution Incorrect placement of the pebbles, e.g. on top of each other, could have the following consequences:

- the main burner will not ignite properly, which could result in unsafe situations;
- the flame picture will be affected.

6. Control

The appliance is supplied with a wireless black remote control for the user (see appendix 3, fig. 35 (B)). As an option, an orange remote control can be supplied for the installer (see appendix 3, fig. 35 (O)). Controlling the flame height, igniting and switching off take place through the black remote control controlling a receiver. Some fires can also be controlled in an alternative way. These options are described further down in this chapter.

The User Manual describes the operation of the appliance. Including the operation of the remote control and alternative methods of operation.

!Caution Do not ignite the appliance before the gas, discharge and electric connections have been fully installed, first observe the procedure described in chapter 7.3.

6.1 Remote controls

6.1.1 Black remote control for the user

Proceed as follows to make the black remote control ready for use:

- Place the two penlite batteries (AA) in the battery holder of the remote control.
- Make sure the voltage of the atmospheric fire is not switched off for longer than 5 minutes.
- If the remote control does not have the "BND" state, the following operations must be performed: Press the menu button (button with square symbol) on the remote control for at least 10 seconds and then press a few times until "BND" appears on the screen with the receiving symbol.
- Press the "arrow up" and "arrow down" buttons briefly and simultaneously, so that a (flashing) warning triangle and an hourglass appear in the screen as well.
- As soon as logging on is finished, the start screen will appear

!Tip All functions are extensively explained in the supplied user manual.

6.1.2 Orange remote control for the installer

By means of the optionally available orange remote control, it is possible to read all information stored in the receiver. In this way, the last 20 error messages can be retrieved, and it will also be possible to read how many times an error occurred. Moreover, this remote control can also be used to adjust the basic settings and to read the size of the ionization flow. It is also required for a wired Domotics control.

6.2 Alternative control (if applicable)

In addition to the remote control, it is also possible to operate the fire in alternative ways. For this purpose, a Domotics system can be connected to the receiver. This can be a wired or a wireless system. The various possibilities are described below (see appendix 3, fig. 35, 36 and 37).

6.2.1 Wired

Wired connection of the Domotics system to the receiver takes place via a 0-3VDC direct current (see appendix 3, fig. 36 (D)).

!Caution A higher voltage than 3V will damage the receiver and is therefore not permitted.

Tip! In case of Domotics systems with an output voltage of 0-10V, you should switch the voltage back to 0-3VDC. Use a voltage distributor made of resistors. For example, 2200 ohms and 680 ohms. The voltage above 680 ohms resistance can be used on the input of the 0-3VDC. Low ohmic resistors must be used.

By controlling the height of the voltage, the receiver will be able to calculate the position of the fire. Table "B1" in appendix 3, fig. 37 shows the relationship between the voltage and the height of the flame. If you have an appliance with 2 burners, table "B2" will apply. It shows the relationship between the voltage, the height of the flame and the number of burners.

Proceed as follows when connecting the Domotics system to the receiver:

- Connect the 0-3VDC signal to the connector, to which a black and yellow wire are connected (see appendix 3, fig. 36 (D)).
- Use the orange remote control to select the option for a wired connection: go to position 8 in the first menu and select an appliance with single burner (option 2) or an appliance with two burners (option 3). For this, read the manual of the orange remote control.

!Caution The yellow wire is the + pole, the black wire is the – pole. Always connect ‘- to -’ and ‘+ to +’.

6.2.2 Wireless

The wireless connection is divided into 2 types:

- Connection via a ‘modbus’ protocol.
- Control via an application.

!Caution Only 1 type of wireless connection is possible on the communication module.

6.2.2.1 Connection via ‘modbus’ protocol

Wireless connection of a Domotics system to the receiver is possible via a connection according to the ‘modbus’ protocol. Such a connection can only be established with a communication module (see Appendix 3, fig. 35 (W)). This module can be ordered from DRU. This communication module translates the ‘modbus’ protocol from the Domotics system into a wireless signal to the receiver.

When connecting a Domotics system via the communication module to the receiver, proceed as follows:

- Using the remote control, test whether the location where you want to place the communication module is within the receiver's range.
- Place the remote control on this location and test the reception sensitivity (RSSI).
- Press the on/off button and down arrow at the same time. The value that is now visible, must be between -20 and -70 (see User Manual, "Reception Sensitivity"). If needed, hold the remote control closer to the appliance in order to improve the reception.
- Connect the communication module by means of an RJ45 plug, according to the instructions in the manual that is supplied with this module.
- Now follow the steps described in the ‘modbus’ protocol manual. It is available from the supplier of the domotics system.

6.2.2.2 Control via application

If the fire is operated via a tablet using the application (iOS or Android), a communication module is required. This module can be ordered from DRU.

In order to control the fire via an application, proceed as follows:

- Using the remote control, test whether the location where you want to place the communication module is within the receiver's range.
- Place the remote control on this location and test the reception sensitivity (RSSI).
- Press the on/off button and down arrow at the same time. The value that is now visible, must be between -20 and -70 (see User Manual, "Reception Sensitivity"). If needed, hold the remote control closer to the appliance in order to improve the reception.
- Connect the communication module by means of an RJ45 plug, according to the instructions in the manual that is supplied with the communication module.
- Use the instructions for the application in order to install it.

The application 'DRU Control' is available in the AppStore, at GooglePlay or our website: www.drufire.co.uk

7. Final inspection

In order to check whether the appliance is working properly and safely, you must perform the following inspections before the appliance is put into operation.

7.1 Gastightness

!Caution All connections must be gastight. Check the connections for gastightness.
The gas control may be subjected to a maximum pressure of 50 mbar.

7.2 Gas pressure/line-pressure

The burner pressure is set at the factory; see data plate.

!Caution The line-pressure in house installations must be checked, because it can be wrong.

- Check the line-pressure; see Appendix 3, Fig 38 (P1) for the measuring nipple on the gas control.
- Contact the gas company if the line-pressure is not correct.

7.3 Ignition main burner

For igniting the main burner, see the User Manual.

7.3.1 First ignition of the appliance after installation or adjustments.

!Caution - After installation, or after work has been performed, you should ignite the appliance for the first time without the glass window. If necessary, bleed the gas pipe.

Follow the procedure described below:

- If required, remove the glass window;
- Start the ignition procedure as described in the user manual;
- If the main burner does not ignite:
 - Reset the system by pressing the buttons 'arrow up' and 'arrow down' simultaneously;
 - Repeat the ignition procedure until the main burner ignites;

!Caution After each attempt to ignite, the system must be reset.

- Consult the diagram with error messages (Appendix 1) if this does not succeed after a few attempts;

The appliance ignites at 50%. After ionization has been detected, the appliance will modulate to 100%. This detection will have to take place within 15 seconds, or else the appliance will enter error mode. If applicable, the second valve will switch to ignite the second burner. Here, you can hear a clear 'click' sound.

- Check whether the main burner continues to burn;
- If the main burner does not continue to burn:
 - Reset the system as described and repeat the ignition procedure until the main burner continuous to burn.

!Caution The system can be reset and re-ignited three times in a row at maximum. After that the system will enter hard lock-out and you will have to wait for half an hour before you can make a new attempt.

- Consult the malfunction search diagram (Appendix 1) if this does not happen after a few attempts;
- Switch off the appliance;
- Then mount the glass window as described from chapter 5.10;
- Repeat the ignition procedure a few times and perform the checks described in chapter 7.3.2;
- From now on, the main burner should ignite smoothly.

!Tip When checking whether the main burner continuous to burn, it is possible that it switches off after 15 seconds. In that case, this will be caused by the fact that there is no ionization detection and because the glass window has not been placed. In this case you may presume that the main burner continuous to burn.

- !Caution**
- Always wait 5 min. before re-igniting the appliance;
 - No changes may be made to the gas control.

7.3.2 Main burner

- !Caution**
- The ignition electrode should ignite the main burner within a couple of seconds and without popping.
 - The main burner(s) must cross the full burner smoothly and without popping and continue to burn.
 - If the appliance does not ignite after three restarts and enters hard lockout, it may never be reset by disconnecting it from the power supply. If a restart is necessary after all: remove the glass pane and make sure the gas is able to escape from the appliance. After this, the appliance may be disconnected from the power supply for 10 seconds. After these 10 sec., the power supply may be reconnected. Ignite the appliance in the same way as the first ignition, as indicated in section 7.3.1.

- Check operation of the main burner from a cold condition.
- If sparks are determined between the ignition electrodes, the main burner should burn within a few seconds.

!Tip The flame picture and a good flame transfer can only be properly judged if the glass window is installed.

Use the malfunction search diagram (Appendix 1) if the ignition of the main burner does not comply with the above-mentioned requirements.

7.4 Flame picture

The flame picture can only really be assessed when the appliance has been burning for several hours. Volatile components from paint, materials, etc., which evaporate in the first hours, will affect the flame picture.

!Caution If the chimney breast is made of stone-like materials or has a plaster finish, the appliance may only be put into operation 6 weeks after the chimney breast has been placed, in order to prevent shrinkage cracks.

- Check whether the flame picture is acceptable.
- Consult the malfunction search diagram (Appendix 1) if the flame picture is not acceptable, in order to solve the problem.

8. Maintenance

Once a year the appliance should be checked, cleaned and, if necessary, repaired by a competent installer in the field of gas heating and electricity.

Check at least whether the appliance is working properly and safely.

- !Caution**
- Close the gas tap when performing maintenance work;
 - Check the gastightness after repair;
 - Make sure there is no voltage on the appliance.

- If required, clean the following components:
 - the glass pane(s).

- !Caution**
- Remove/place the glass pane(s) as described from section 5.10;
 - Remove the deposit on the inside of the glass pane(s) with a damp cloth or a non-abrasive detergent such as copper polish or ceramic hot plate cleaner;
 - Avoid/remove fingerprints on the glass pane(s), since otherwise they will burn into the surface;
 - Replace broken and/or cracked glass panes as described from section 5.10.

!Caution If necessary, place back the wood or pebble set correctly; for this, see from section 5.10.

- Inspect the flue gas discharge system.

!Caution You must always perform a final inspection.

- Perform the inspection as described in chapter 7.

8.1 Parts

Parts to be replaced are available at your supplier.

9. Delivery

You must explain to the user how to operate the appliance. You must give him/her instructions on putting it into operation, the safety measures, the operation of the remote control and the annual maintenance (see the User Manual).

- !Caution**
- Tell the user to close the gas tap immediately in case of malfunctions/bad performances and contact the installer in order to prevent dangerous situations;
 - Indicate the location of the gas tap;
 - Point out the precautions in the user manual against unintended ignition by other wireless remote controls such as car keys and garage door openers;
 - Point out the 230 Volt connection.
- Instruct the user about the appliance and the remote control.
- When the appliance is taken into operation, point out that
- in order to avoid cracks in a chimney breast made of stone-like materials or finished with plaster, it should dry for at least 6 weeks prior to putting the appliance into operation;
 - when the appliance is stoked up for the first time, volatile components evaporate from paint, materials, etc.. (Also first read chapter 3 of the user manual !);
 - when evaporating, the appliance should preferably be set at the highest level;
 - the room should be well ventilated.
- Give the manuals to the user (all manuals should be stored near the appliance).

10. Malfunctions

In Appendix 1 you will find an overview of malfunctions that might occur, the possible causes and the remedies.

Appendix 1 Malfunctions

Error messages			
Error code	Problem	Possible cause	Remedy
F01	Communication loss between receiver and burner device	Communication cable does not make contact	Make sure the connectors of the communication cable make proper contact
		Communication cable defective	Replace communication cable
F02	Receiver overheated (60° above room temperature)	Poor ventilation at receiver	Improve ventilation at receiver
		Receiver makes contact with hot parts	Move receiver in such a way that there is no more contact with hot parts
F03	Internal (receiver) NTC sensor does not work correctly	Receiver is defective	Replace the receiver
F04	External NTC sensor, does not work correctly	External NTC sensor or cabling defective.	Replace NTC sensor or replace cabling
F05	Internal safety error	Receiver is defective	Replace receiver
F06	Communication loss between transmitter and receiver	Transmitter is out of the receiver's range	Make sure the transmitter is near the receiver
		Obstacles between transmitter and receiver may interfere with the signal	Remove possible obstacles between transmitter and receiver
		Transmission power is too weak	Check transmission power (see User Manual chapter 10)
F08	No ionization	No sparks	Check/replace the spark electrodes
		No gas	Check whether there is gas
			When using PowerVent, check whether the gas valve opens
		Poor flame transfer main burner	Check position blocks/chips
			If necessary, remove dust from burner openings
		No good flame under ionization pin (suffocating flame)	Glass pane strips not placed correctly
			Check restriction and air inlet guide setting
			When using PowerVent, check pressure setting
		Ionization pin placed incorrectly	Place it on the right location
		Ionization pin blocked (measure ionization flow when > 0 and < 1.8 uA)	Remove any vermiculite or chips from the burner

Error messages			
Error code	Problem	Possible cause	Remedy
F08 (follow-up)		Ionization pin defective (measure ionization current when 0)	Replace the ionization pin
F12	ESYS is not released	ESYS is in hard-lock	Wait half hour until ESYS resets itself.
F13	Flame loss when only the main burner is on	Gas has fallen away	Check gas supply
		Gas control defective (see "A" in app. 3, fig. 38)	Replace the gas control
		Suffocation due to poor flue gas channel	Check the concentric system
			Check the setting of the appliance
		Suffocation when using PowerVent	Check the pressure setting of the PowerVent system
		24 hour check control	Reset with remote control (consult Powervent manual)
F14	Flame loss if both burners are on.	Gas has fallen away	Check gas supply
		Gas control defective (see "A" in appendix 3, fig. 38)	Replace the gas control
		Suffocation due to poor flue gas channel	Check the concentric system
			Check the setting of the appliance
		Suffocation when using PowerVent	Check the pressure setting of the PowerVent system
F15	No burner device (see "C" in appendix 3, fig. 38)	Burner device came loose from burner device	Attach the burner device
		Burner device incorrectly mounted	Mount the burner device correctly
		Pins on the connector on the gas control are bent	Bend them straight
	High limit error	High limit bridge defective	Check High limit bridge ESYS
F16	Hardware Error ESYS	ESYS defective (burner device)	Replace ESYS (burner device)
F17	Disable contact is closed	Window is open. (if this contact is present)	Close window
		A bridge has been made across the Disable contact.	Remove bridge on ESYS (burner device)

Appendix 2 Tables

Table 1: Parts included with the delivery	
Part	Number
Wood set / pebble set	1x
Control hatch	1x
Control hatch manual	1x
Installation manual	1x
User manual	1x
Decorative strip left Metro 150XT RCH (Tunnel RCH)	1x (2x)
Decorative strip right Metro 150XT RCH (Tunnel RCH)	1x (2x)
Decorative strip below Metro 150XT RCH (Tunnel RCH)	1x (2x)
Gauge for restrictor slide	1x
Restrictor slide	1x
Key bolts M8x 140x50	2x
Hexagonal nut M8	2x
Washer 8.4 mm	2x
Spare self-tapping screws for mounting the glass panes	4x
Socket spanner 8 mm	1x
Remote control	1x
Compression fitting 15 mm x G3/8"	1x
Mains cable NL or UK	1x
Glow material	1x

Table 2: Technical data

Table 2: Technical data				
Product name	Metro 150XT RCH / Metro 150XT Tunnel RCH			
Type of appliance	Built-in			
Combustion	Closed combustion			
Supply and discharge system	Concentric 200/130			
Flame protection version	Separated ignition / ionization plugs			
Atmosphere safety	No			
Explosion hatch	Yes			
Ventilation hole chimney breast	200 cm ²			
Type	C11/C31/C91			
Type of gas		G20	G25/G25.3	G31
Burner pressure	mbar	13.5	17.5	27
Nominal heat input (Hs)	kW	15.2	14.6	15.2
Nominal heat input (Hi)	kW	13.7	13.2	13.7
Nominal output	kW	10.8	10.3	11.1
Consumption	L/h	1427	1562	571
Burner injector	mm	3x Ø 1.85	3x Ø 1.85	3x Ø 1.25
Low setting injector	mm	A*	A*	A*
Burner pressure on low output	mbar	3.9	3.9	6.8
Consumption on low output	L/h	729	694	299
Efficiency class		2	2	2

A* = Adjusting screw

Table 3: Line-pressure when using G31	
Country	mbar
NL / DK / FI / NO / SE / HU / BA / GR	30
FR / BE / IT / PT / ES / GB / IE	37
D	50

Permissibility and conditions concentric system with wall terminal

Table 4: Conditions for setting the appliance					
Total number of meters vertical pipe length	Total number of meters horizontal pipe length (excluding wall terminal)	See Figure	Air inlet guide	Restrictor slide	Distance of restriction in mm
0,8 ¹⁾ - 4	0 - 1 ²⁾	5	YES	NO	OPEN
0,8 ¹⁾ - 4	>1 - 5	5	NO	NO	OPEN

- 1) minimum length
- 2) factory setting

!Caution In case of a wall terminal, you should always use a diameter of 200/130.

Table 5: Determining permissibility concentric system with roof terminal

G20/G25 G25.3/G31	Total number of meters horiz. pipe length	Total no. of meters vertical and/or sloping pipe length											
		1 ¹⁾	2	3	4	5	6	7	8	9	10	11	12
no bends	0	B	B	B	C	C	C	C	C	D	D	D	D
2 bends	0	A	A	B	B	B	C	C	C	C	C	D	D
	1		A	A	B	B	B	C	C	C	C	C	
	2			A	A	B	B	B	C	C	C		
	3				A	A	B	B	B	C			
	4					A	A	B	B				
	5												
3 bends	0	A	A	A	B	B	B	C	C	C	C	C	D
	1		A	A	A	B	B	B	C	C	C	C	
	2			A	A	A	B	B	B	C	C		
	3				A	A	A	B	B	B			
	4					A	A	A	B				
	5												
4 bends	0	A	A	A	A	B	B	B	C	C	C	C	C
	1		A	A	A	A	B	B	B	C	C	C	
	2			A	A	A	A	B	B	B	C		
	3				A	A	A	A	B	B			
	4					A	A	A	A				
	5												
5 bends	-												

☐ = Situation is not permissible

¹⁾ minimum length

Table 6: Conditions for the adjustment of the appliance with a roof terminal

G20/G25/G25.3/G31			
Situation	Air inlet guide	Restrictor slide	Distance restrictor. in mm
A	NO	NO	OPEN
B	YES	NO	OPEN
C	YES	YES	55
D	YES	YES	40

!Caution If a roof terminal without bends is used, you must first connect a 0.8 metre concentric pipe with a 200/130 mm diameter vertically to the appliance. After the first metre, reduce the diameter to 150/100 mm

!Caution If a roof terminal with bends is used, you must first connect a 0.8 metre concentric pipe with a 200/130 mm diameter vertically to the appliance. Make the system with a 200/130 mm diameter, and reduce the diameter to 150/100 mm after the last bend.

Appendix 3 Figures

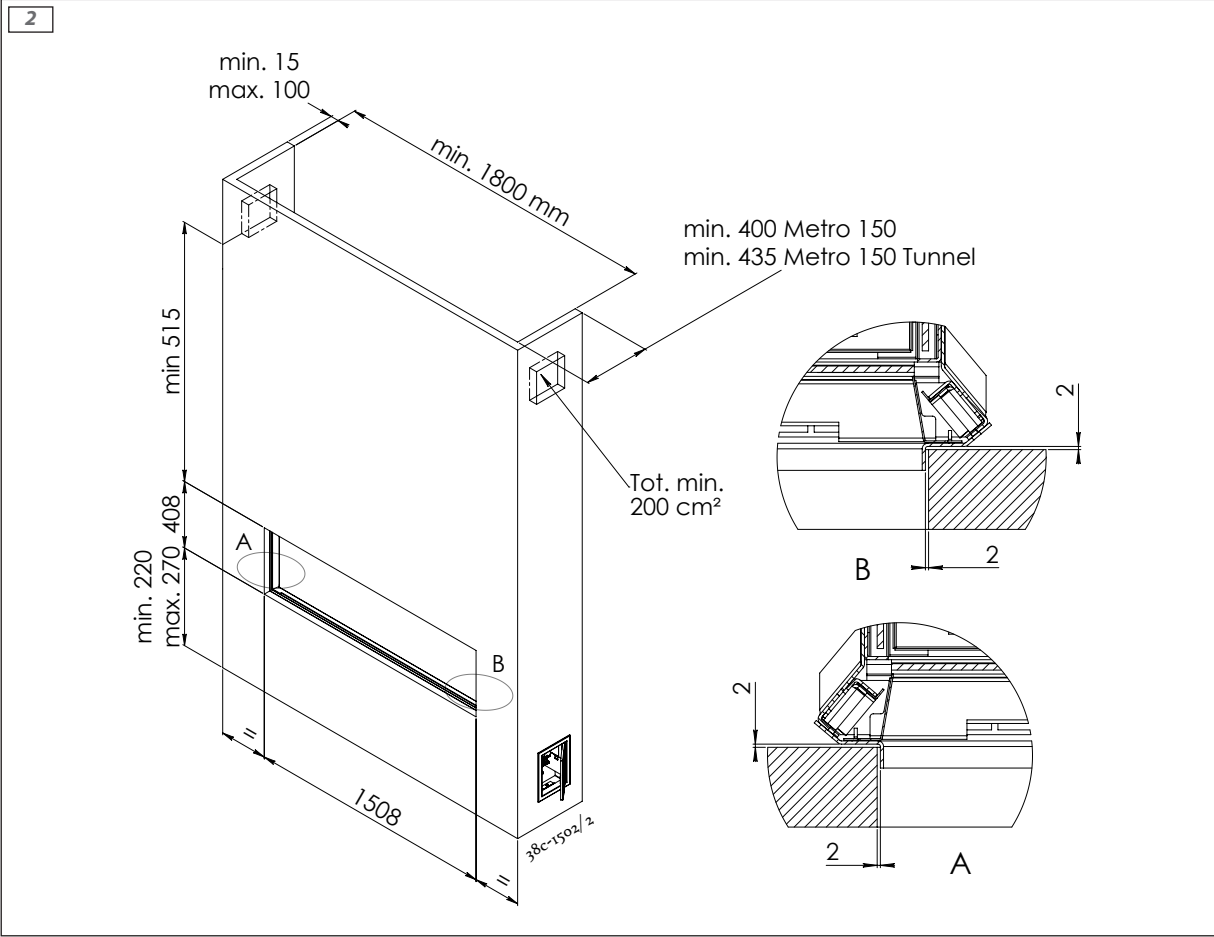
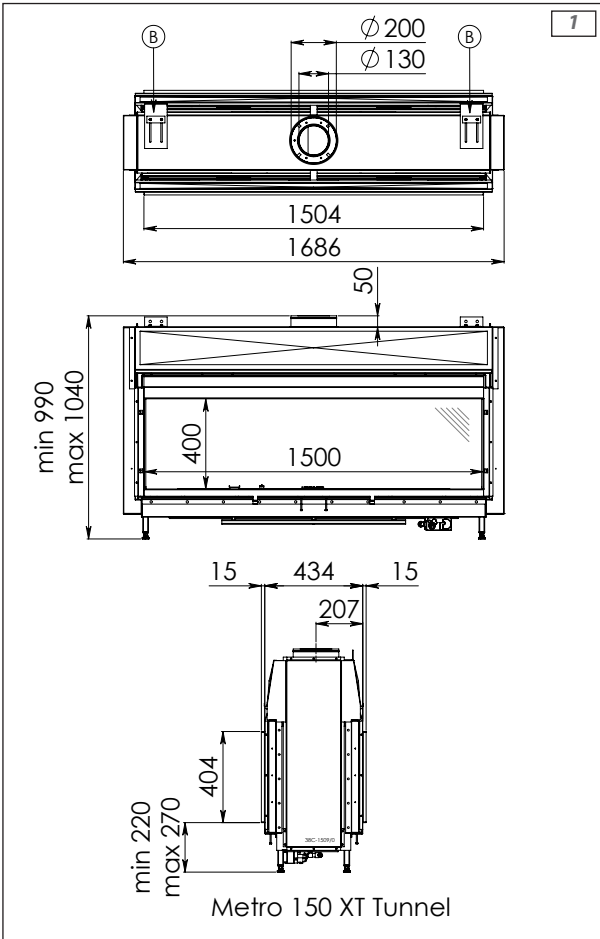
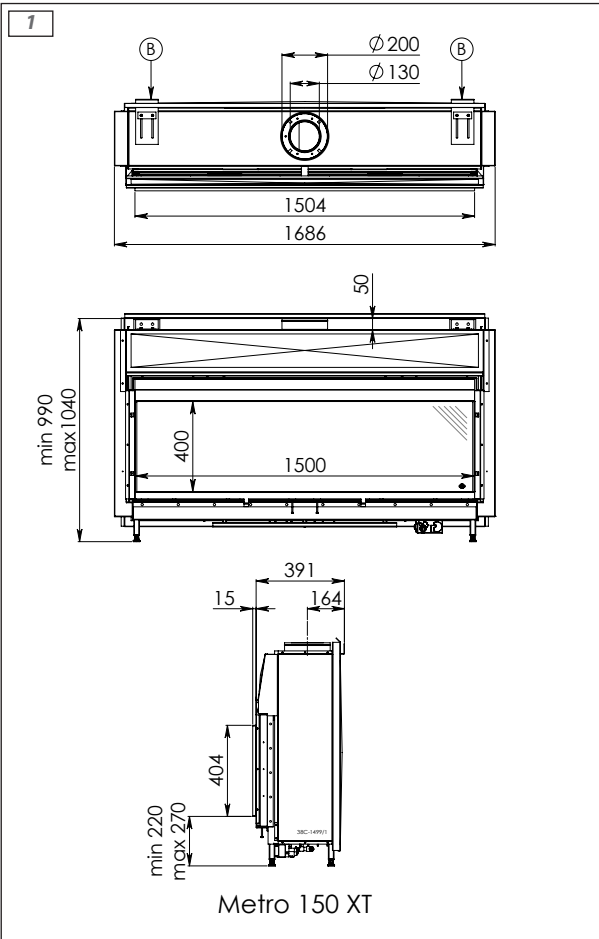

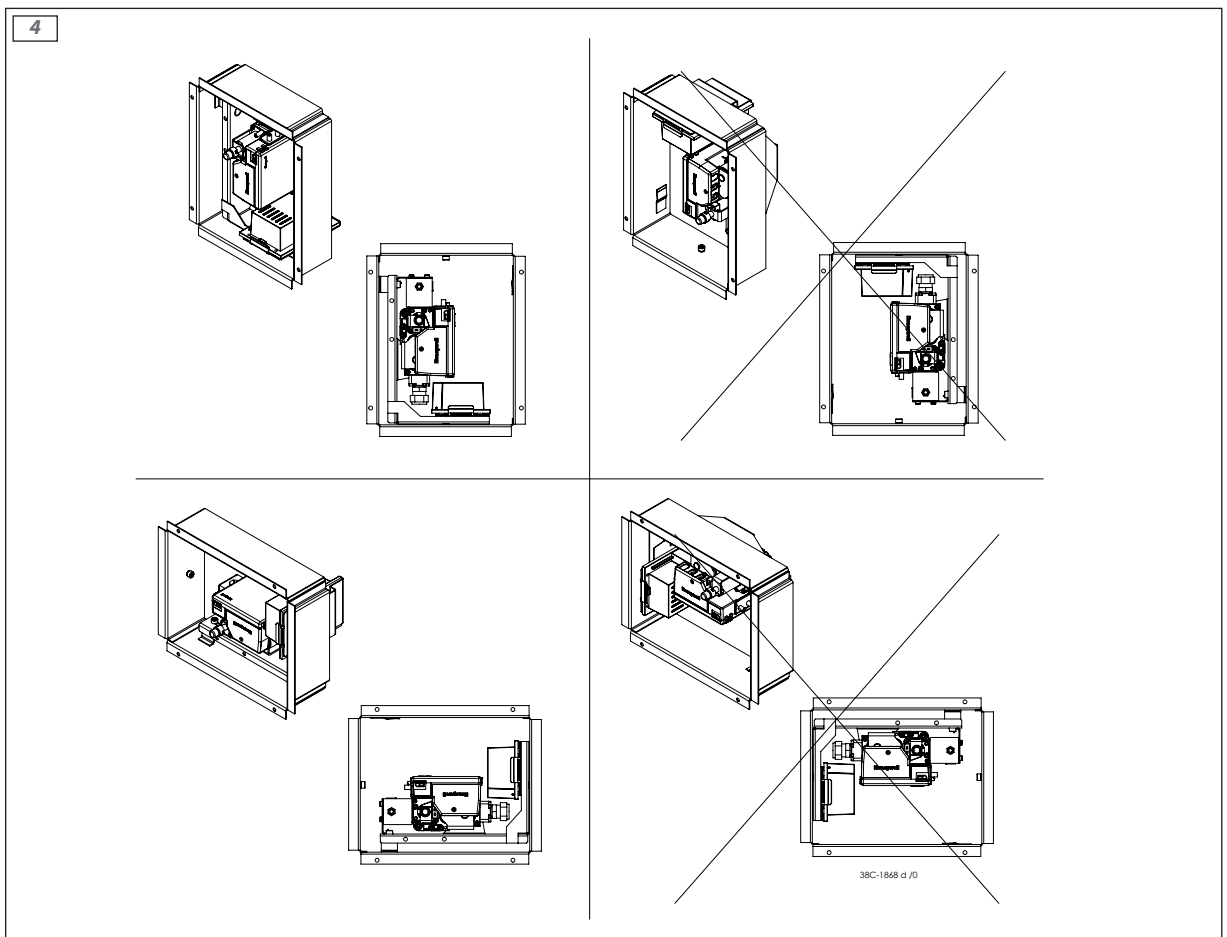
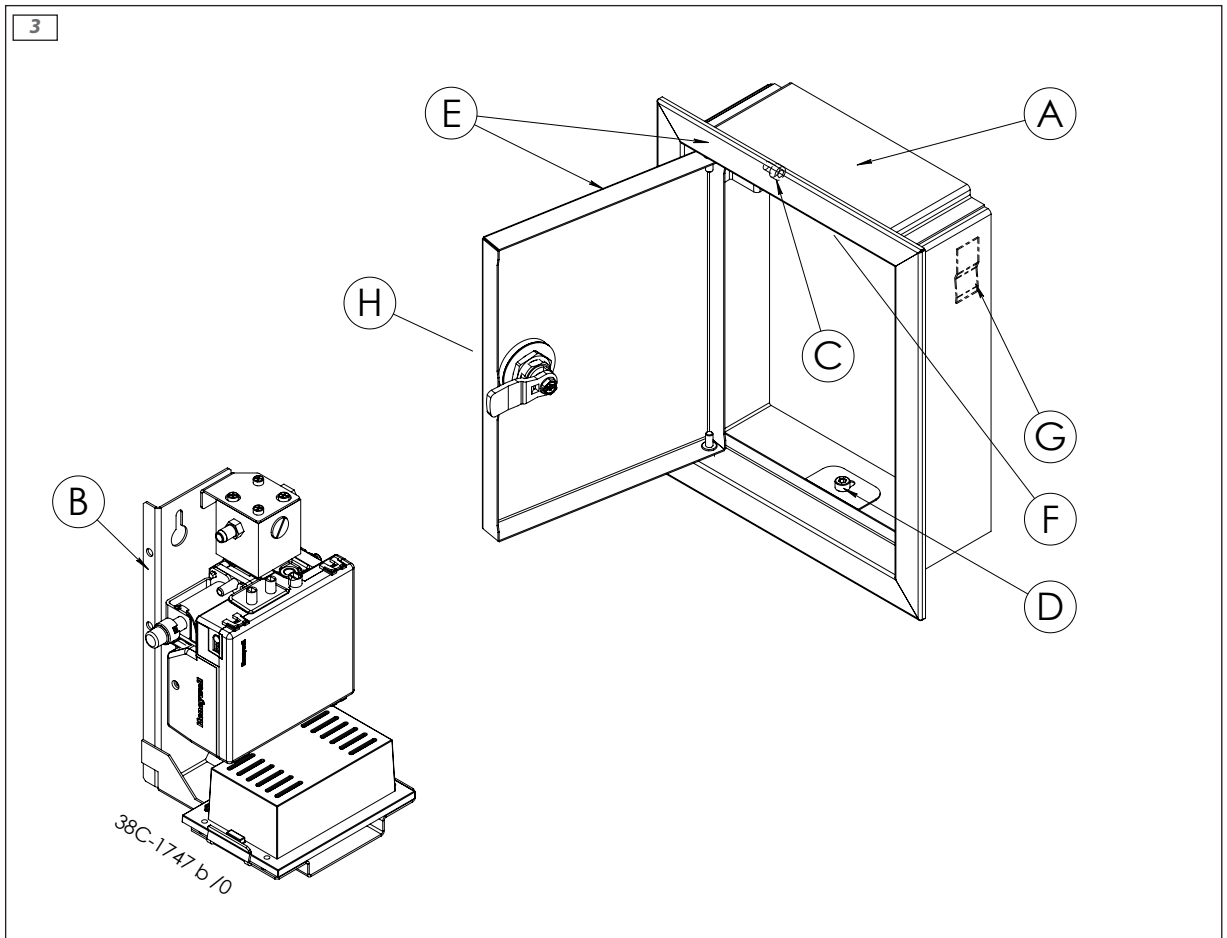

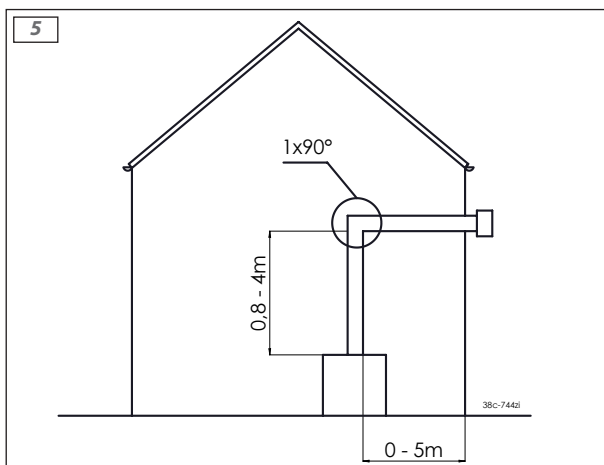



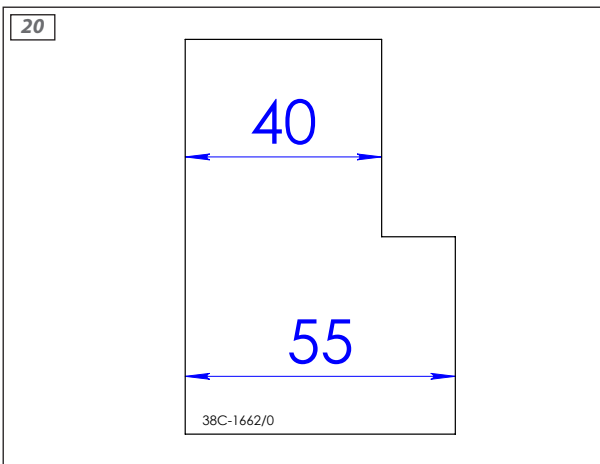
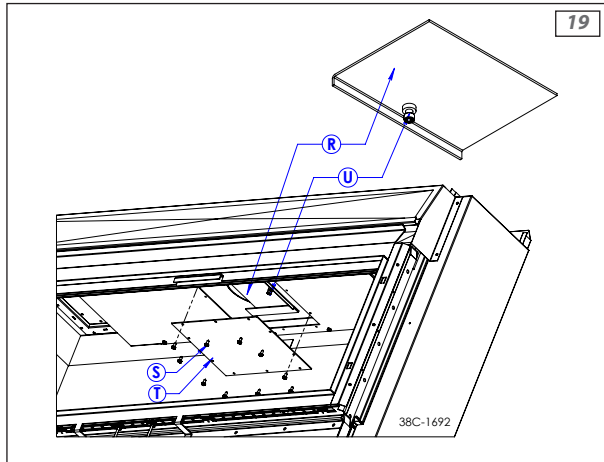
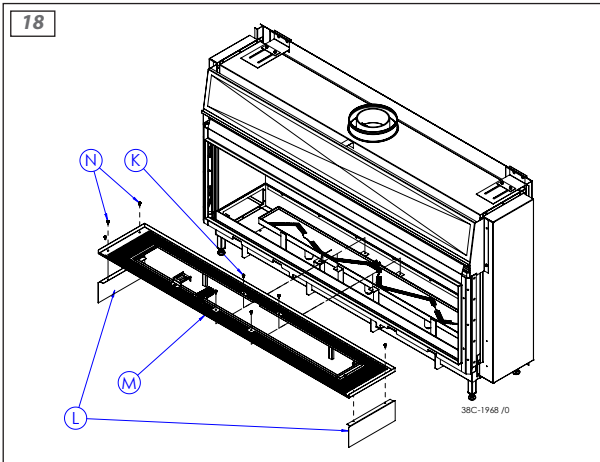

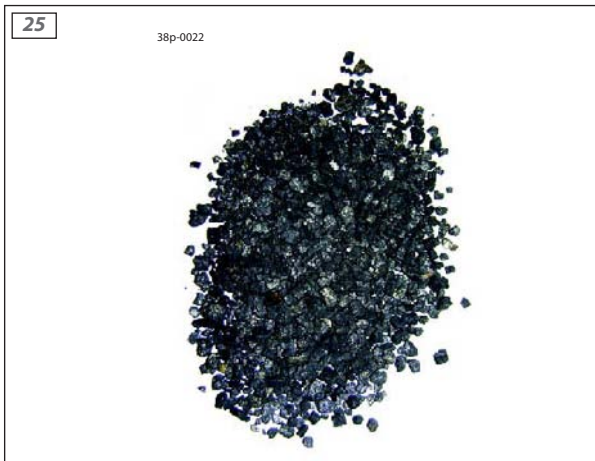

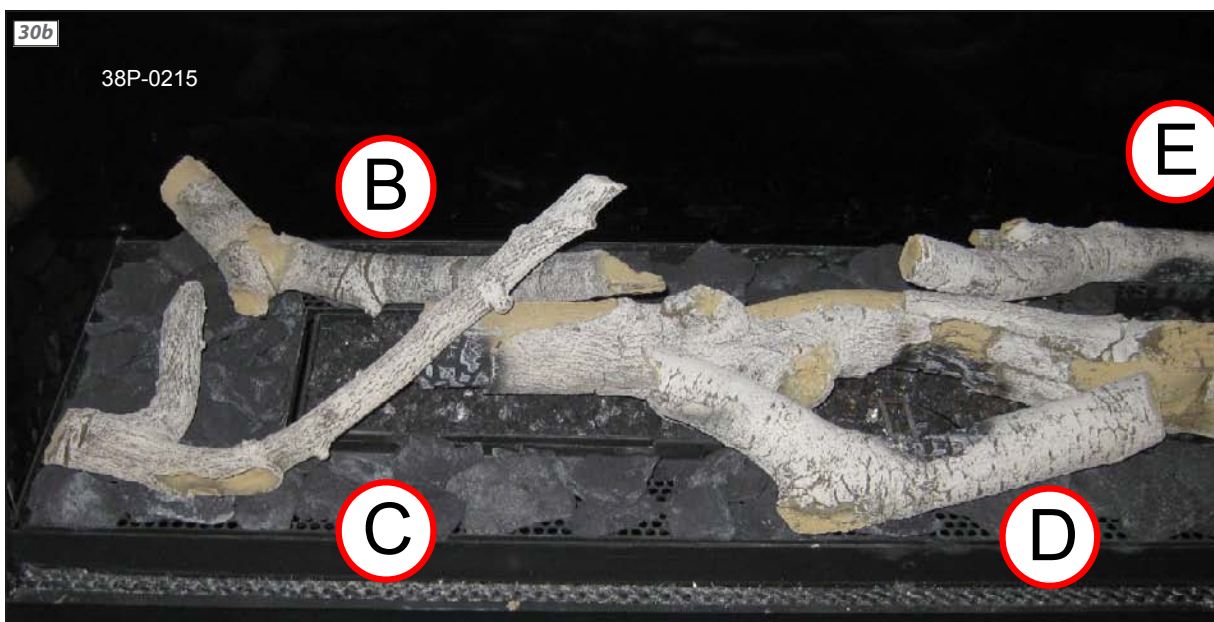
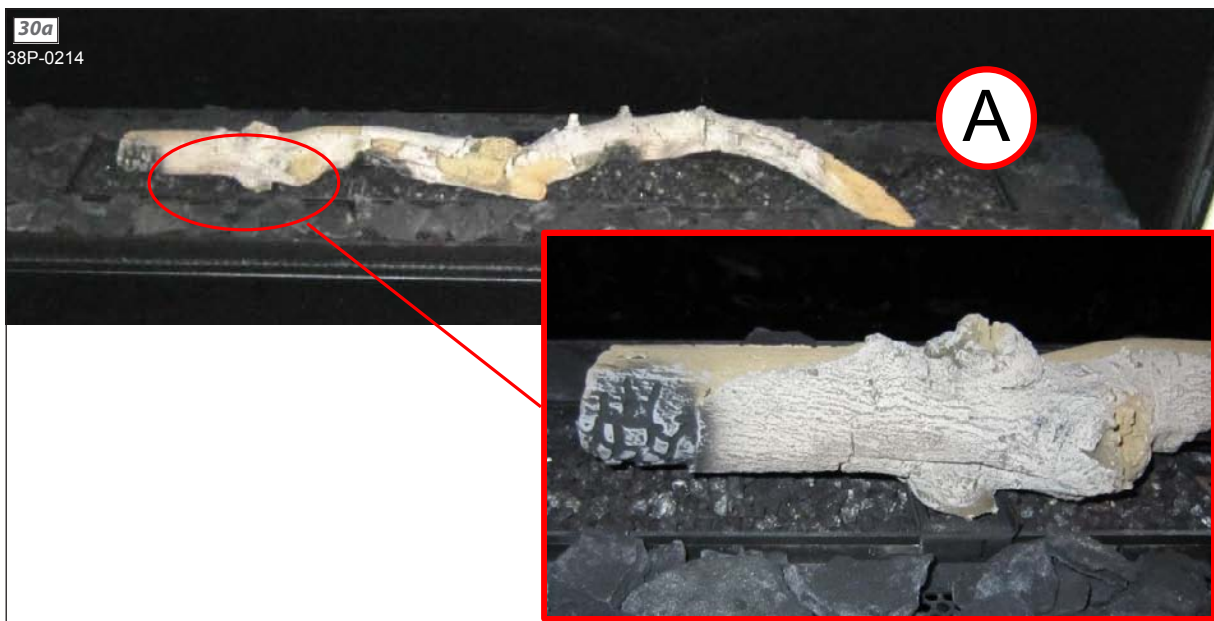
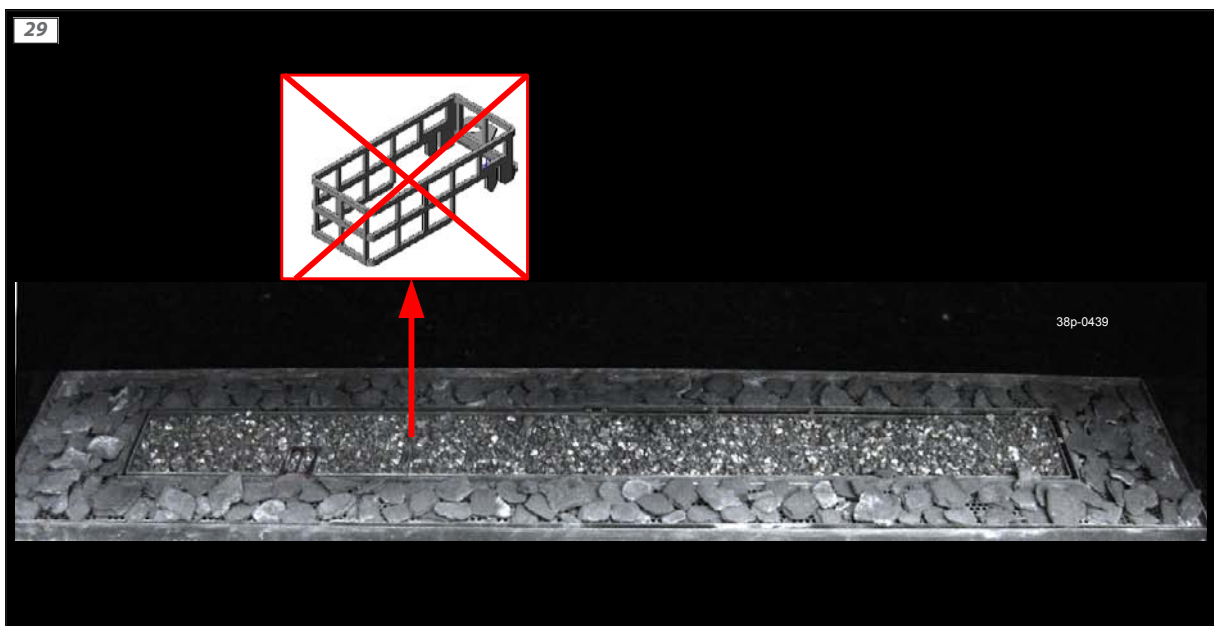

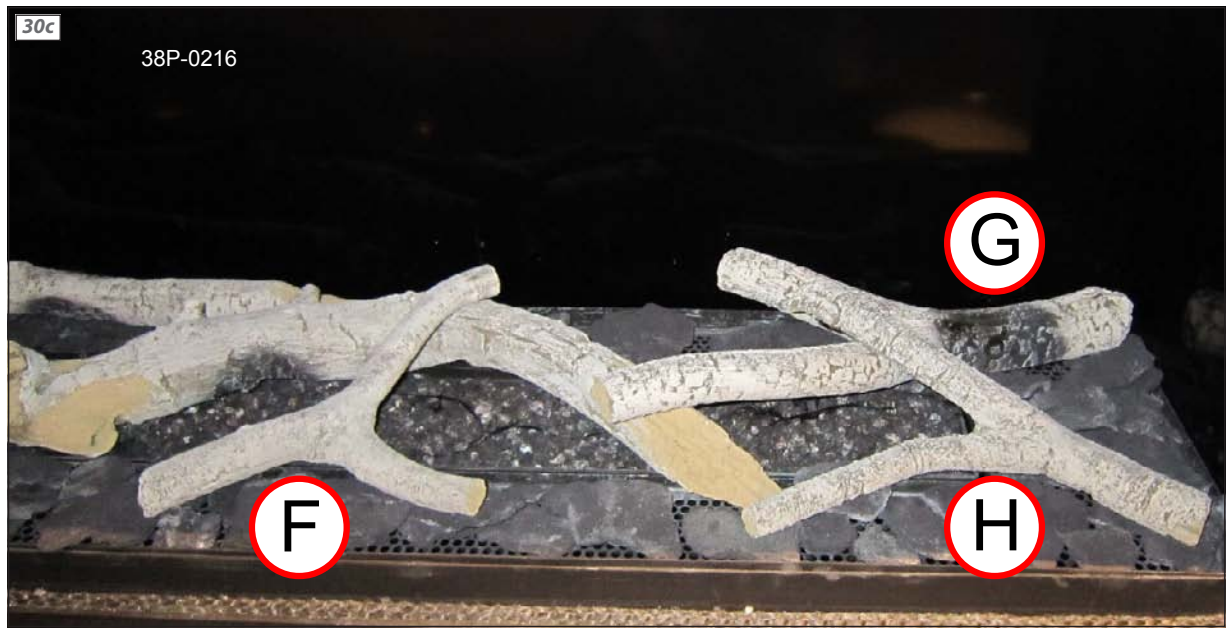

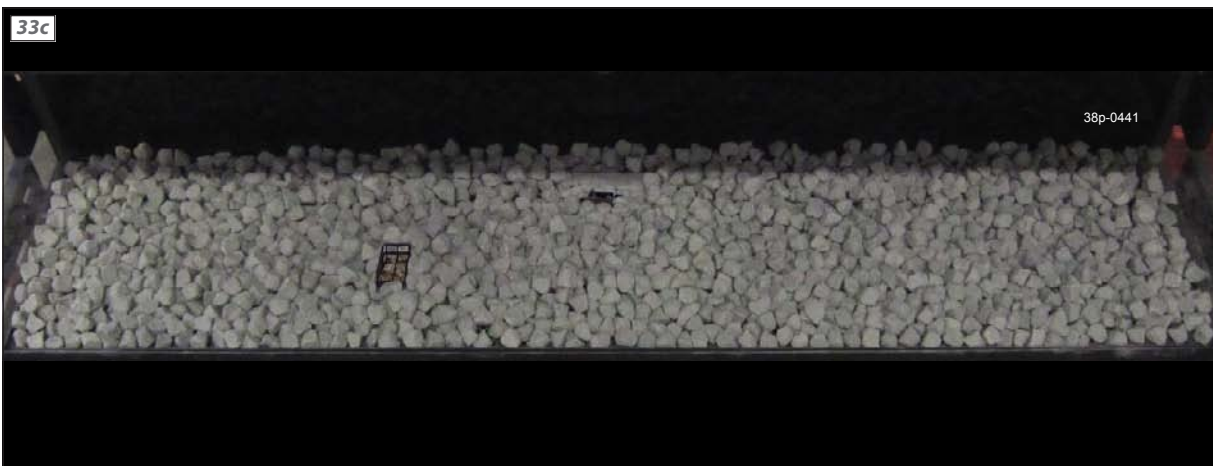
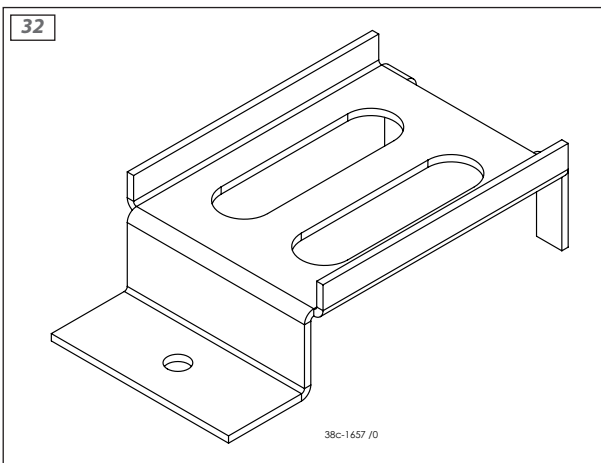

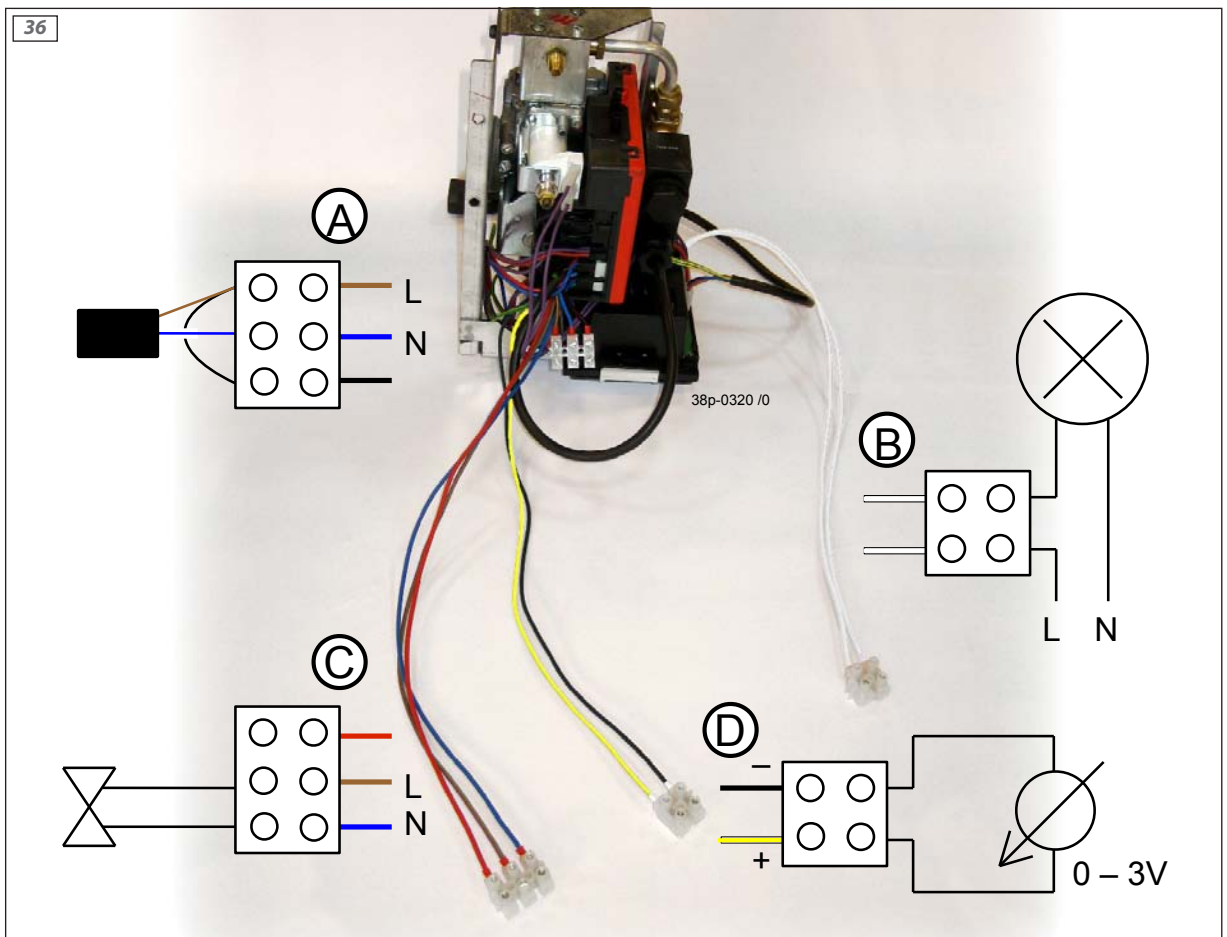
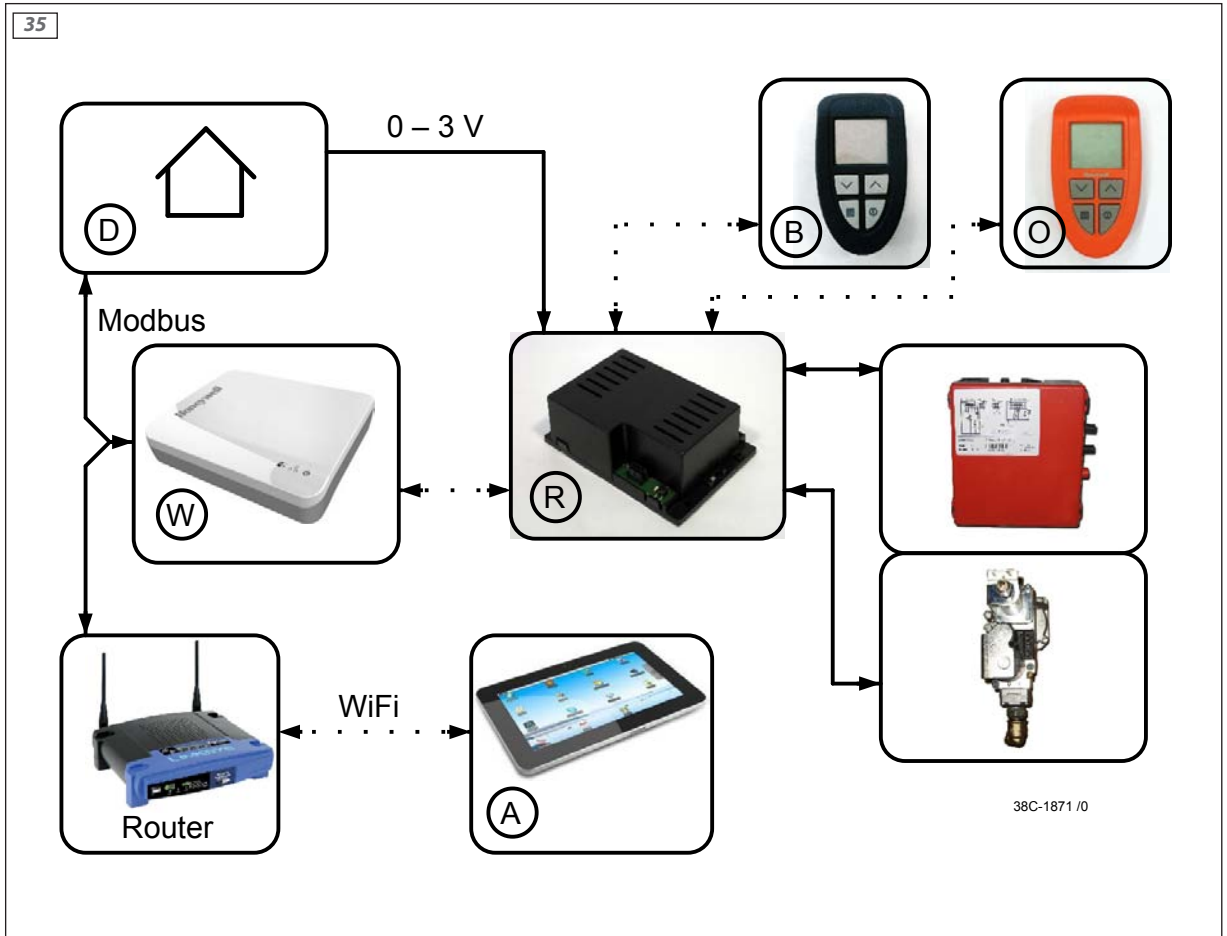









37

B1 				B2  			
B	U			B	U		
1	0,00 VDC	0%	I	1	0,00 VDC	0%	I
1	0,08 VDC	3%	I	1	0,08 VDC	6%	I
1	0,16 VDC	6%	I	1	0,16 VDC	13%	I
1	0,23 VDC	9%	I	1	0,23 VDC	19%	I
1	0,30 VDC	13%	I	1	0,30 VDC	25%	I
1	0,37 VDC	16%	I	1	0,37 VDC	31%	I
1	0,43 VDC	19%	I	1	0,43 VDC	38%	I
1	0,49 VDC	22%	I	1	0,49 VDC	44%	I
1	0,55 VDC	25%	I	1	0,55 VDC	50%	I
1	0,61 VDC	28%	I	1	0,61 VDC	56%	I
1	0,66 VDC	31%	I	1	0,66 VDC	63%	I
1	0,71 VDC	34%	I	1	0,71 VDC	69%	I
1	0,76 VDC	38%	I	1	0,76 VDC	75%	I
1	0,81 VDC	41%	I	1	0,81 VDC	81%	I
1	0,86 VDC	44%	I	1	0,86 VDC	88%	I
1	0,90 VDC	47%	I	1	0,90 VDC	94%	I
1	0,94 VDC	50%	I	1	0,94 VDC	100%	I
1	0,98 VDC	53%	I	2	0,98 VDC	6%	I
1	1,02 VDC	56%	I	2	1,02 VDC	13%	I
1	1,06 VDC	59%	I	2	1,07 VDC	20%	I
1	1,10 VDC	63%	I	2	1,10 VDC	25%	I
1	1,14 VDC	66%	I	2	1,14 VDC	31%	I
1	1,17 VDC	69%	I	2	1,17 VDC	38%	I
1	1,20 VDC	72%	I	2	1,20 VDC	44%	I
1	1,24 VDC	75%	I	2	1,24 VDC	50%	I
1	1,27 VDC	78%	I	2	1,27 VDC	56%	I
1	1,30 VDC	81%	I	2	1,30 VDC	63%	I
1	1,33 VDC	84%	I	2	1,33 VDC	69%	I
1	1,36 VDC	88%	I	2	1,36 VDC	75%	I
1	1,39 VDC	91%	I	2	1,39 VDC	81%	I
1	1,41 VDC	94%	I	2	1,41 VDC	88%	I
1	1,44 VDC	97%	I	2	1,44 VDC	94%	I
1	1,47 VDC	100%	I	2	1,47 VDC	100%	I
	1,98 VDC	Off >	O		1,98 VDC	Off >	O
	2,00 VDC		O		2,00 VDC		O

38C-1903 /0

38

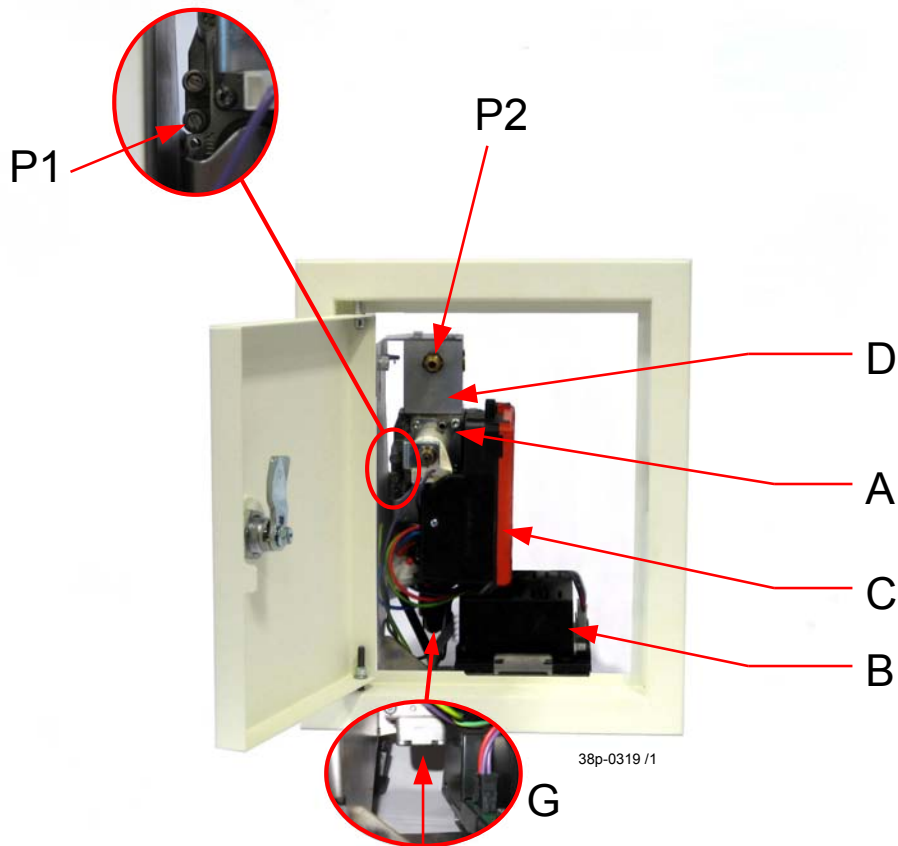



DRU Verwarming B.V.
The Netherlands
Postbus 1021, NL-6920 BA Duiven
Ratio 8, NL-6921 RW Duiven